

# FD-100

# Foam Densifier

## FEATURES

- ◆ Densifies Polystyrene (EPS), Polyethylene (EPE) & Polypropylene (EPP)
- ◆ Processes up to 2000 Lbs. Per Hour of Loose EPS Foam
- ◆ Reduces Foam Volume by Approximately 90 to 1
- ◆ Bag System to Increase Operator Productivity

## BENEFITS

- ◆ Reduces Waste Hauling and Landfill Cost
- ◆ Generates Revenue by Creating a Marketable Product for Recycling
- ◆ Loaner Program

## OPTIONS

- ◆ Molds
- ◆ Foam Shredder

We provide a complete line of foam densifiers to help customers in the collection management of scrap foam material. Our machines process foam onsite by densifying it into a block form which becomes a marketable recycling product. Each machine can densify three main types of foam; polystyrene, polyethylene, and polypropylene. The FD-100 model is the world's first 4 barrel densifier, which gives it the highest production capability available today on the market.

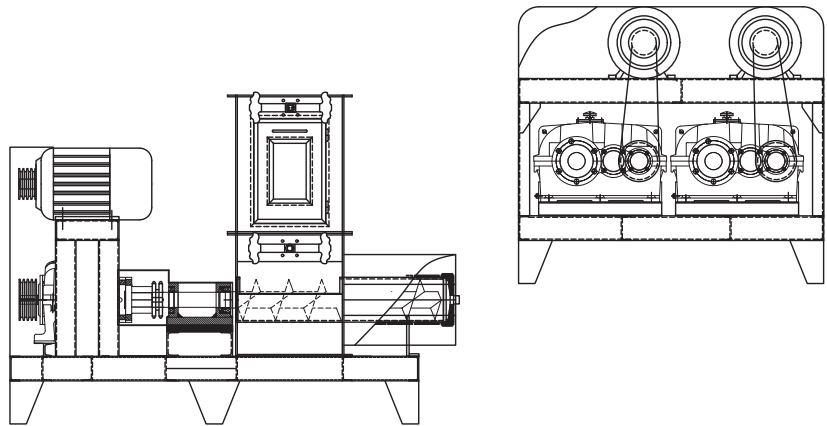

<b>Model &amp; Version</b>	FD-100 V2
<b>Power</b>	115 HP (85.5 kW)
<b>Voltage</b>	230V/460V three-phase
<b>Weight</b>	4500 lbs. (2041 kg)
<b>Maximum Capacity (EPS)</b>	2000 lbs./hour (907 kg)
<b>Feed Opening (W x H)</b>	50" x 50" (1270 x 1270 mm)
<b>Foot Print (D x W x H)</b>	87" x 101" x 112" (2210 x 2565 x 2845 mm)

## CONNECT

E: [wchan@1588ventures.com](mailto:wchan@1588ventures.com)  
[sxie@1588ventures.com](mailto:sxie@1588ventures.com)

T: +1 713.397.9959 or +1 713.449.2199